

2019-2021 T1 Silverado / Sierra Radio Installation Instructions

This installation is very straightforward and requires very few tools including a socket set, a push pin removal tool (or a screwdriver and some patience) good source of light and an automotive pick to release the connector locks. IT IS HIGHLY RECOMMENDED THAT YOU DISCONNECT THE BATTERY BEFORE INSTALLING.

Step 1. Remove the Passenger Side Instrument Panel Insulator:

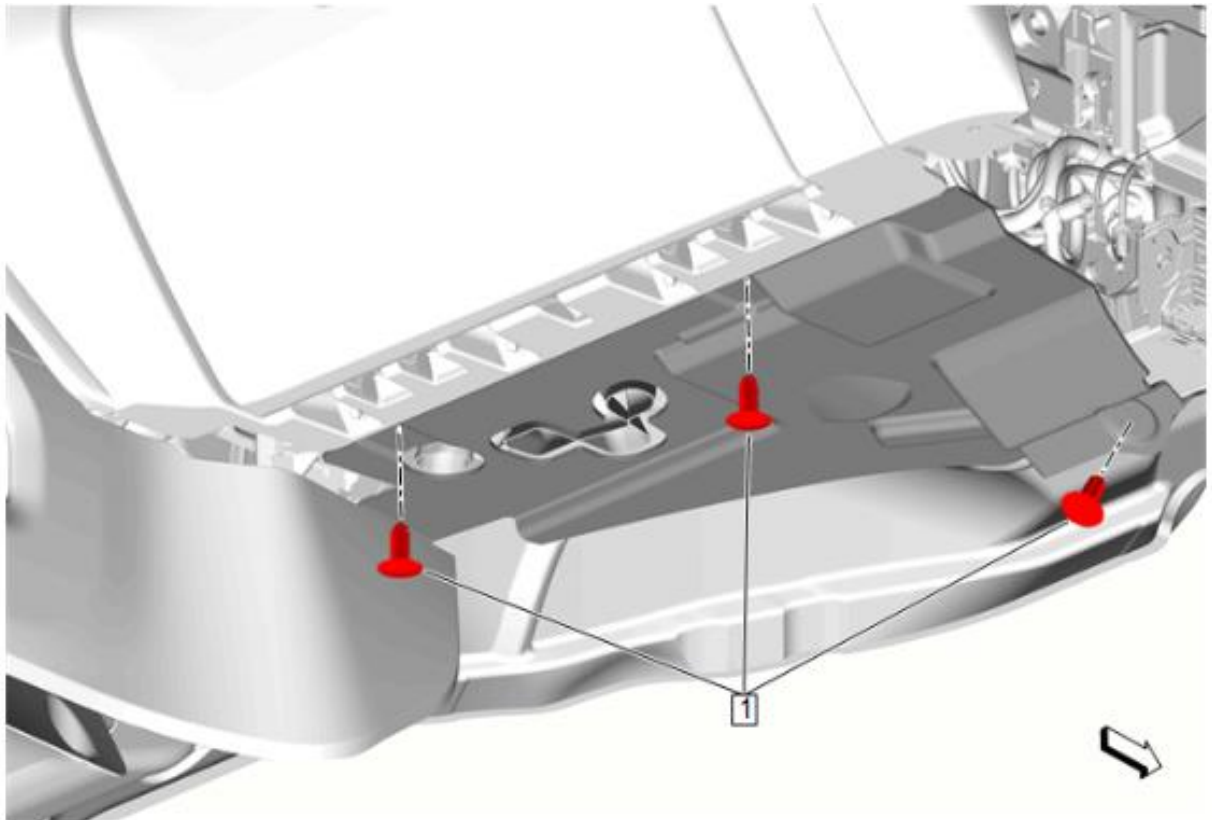

1. Instrument Panel Lower Insulator Retainer(1)»Remove[3x]

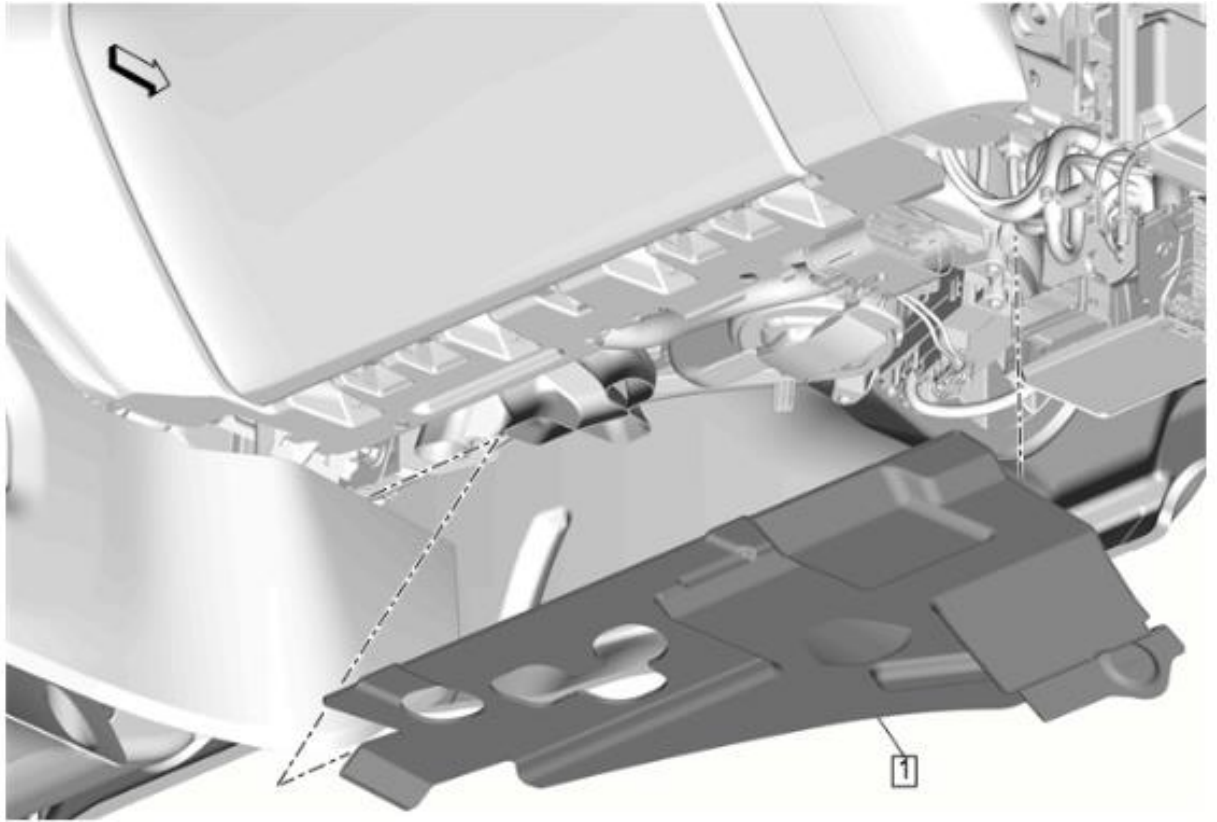

2. Instrument Panel Lower Trim Panel Insulator(1)»Remove

Step 2. Remove the Power Inverter Module:

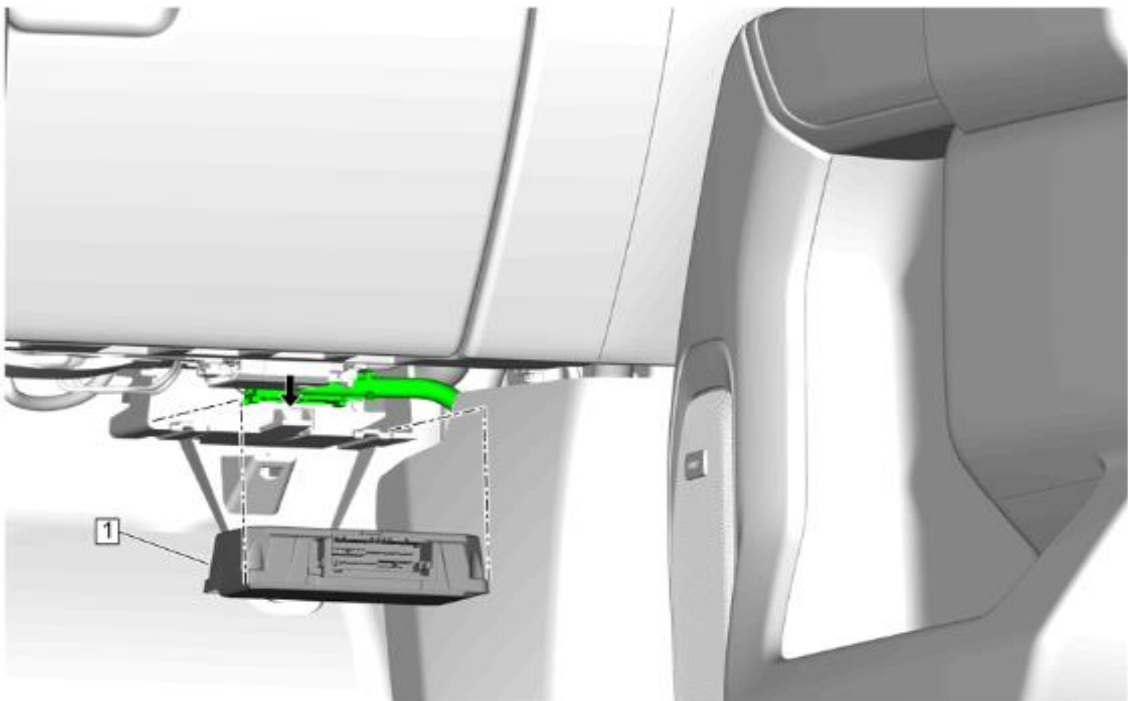

Step 3. Remove the power inverter bracket:

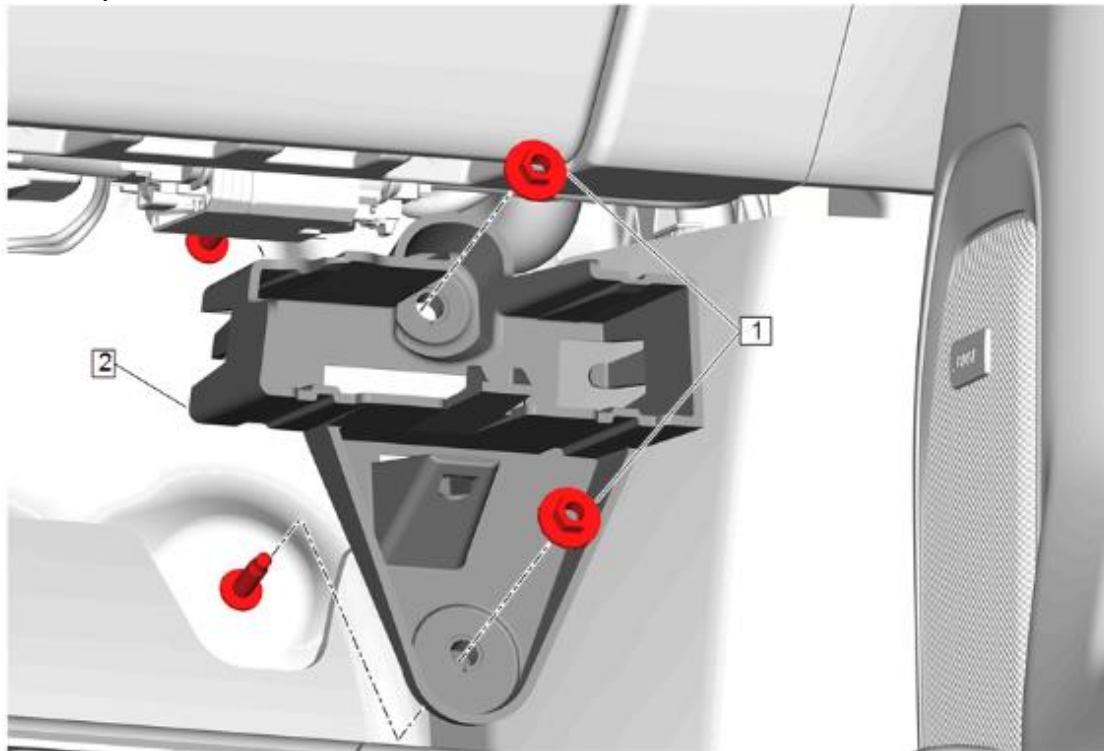

Step 4. Disconnect the wiring harness/cables from the Radio Module. Almost all of these connectors have a Connector Position Assurance (CPA) lock on them which is either red or white. These locks will need to be unlocked (pulled down generally) to unlock the connector before you are able to press in the release tab. This is where you need the automotive pick to work the connector lock down and possibly depress the locks. The Locks on the main wiring harness connectors (black and grey) are WHITE in color and small tabs. All of the locks need to be pulled down/away from the radio just exercise caution and force when doing so. We found it best to run the passenger seat back and simply lay on the passenger side floor facing up for this and just work through the connections one by one.

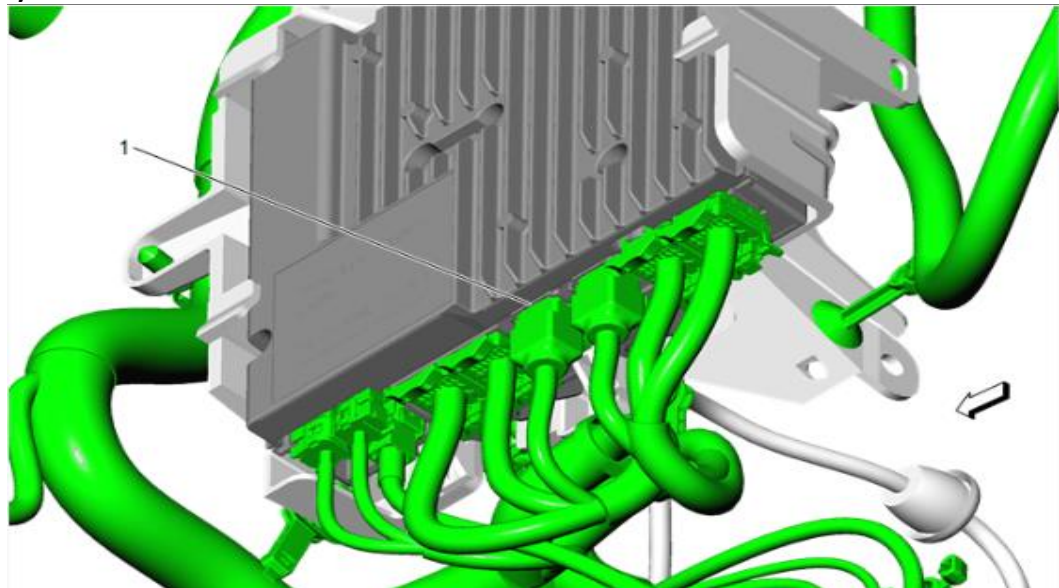

Step 5. Remove the Radio Module. Release the retaining tabs as shown and drop the module down and out of the vehicle.

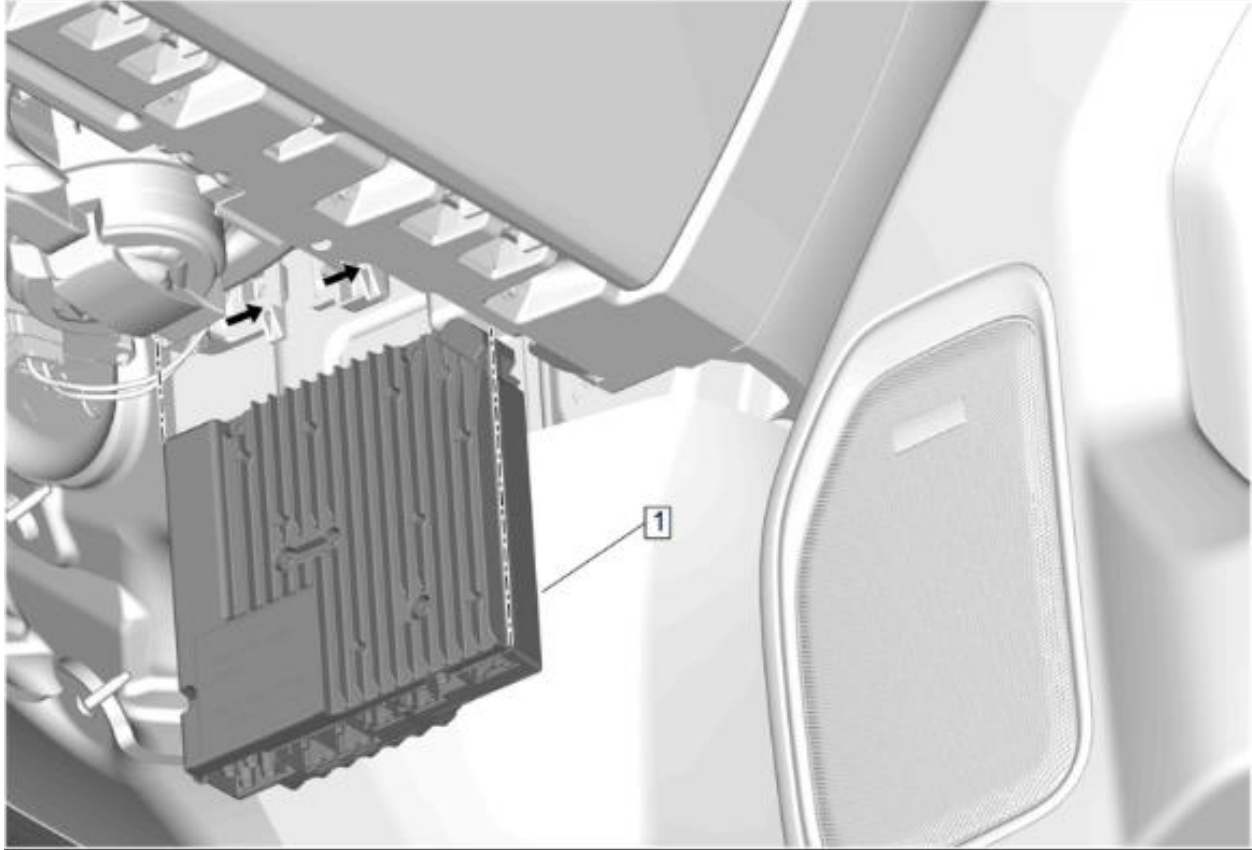

NOTE: There is a large harness running across this area and during several of our installs the routing was tight enough that it warranted either removing the harness from its mounting point and moving it out of the way OR disconnecting one side of it. If you wish to disconnect it you will need to move the red CPA away from the blue locking ring (to the left in the picture below) Then depress the lock on the top (circled) and slide the grey "sleeve" towards the red lock you unlocked it will slide quite a bit and then stop allowing the connector to come apart. Reverse the procedure (and lock it!) to reconnect it.

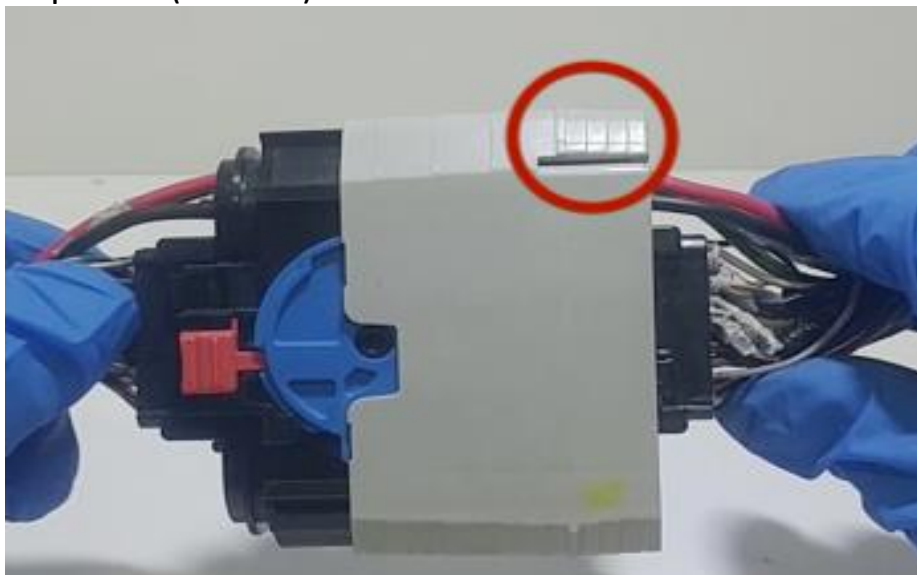

Step 6. Reassembly. Reverse disassembly procedure and reassemble the vehicle. We do recommend reconnecting the battery after plugging the new radio in just to function check everything and make sure it works properly (just in case!) before buttoning everything up. You can also insert the SD card at this time, wait approximately 10 seconds for it to mate to your vehicle then check the navigation function operation. From here if you have an active XM account you'll need to contact them with your new ID if its not already active. We sincerely hope you enjoy your kit we spent a lot of time getting this one "just right" for you!