

2019+ Camaro Radio Installation Instructions

This installation is very straightforward and requires very few tools including a socket set, a push pin removal tool (or a screwdriver and some patience) good source of light and an automotive pick to release the connector locks. IT IS HIGHLY RECOMMENDED THAT YOU DISCONNECT THE BATTERY BEFORE INSTALLING.

Step 1. Remove the passenger side instrument panel closeout

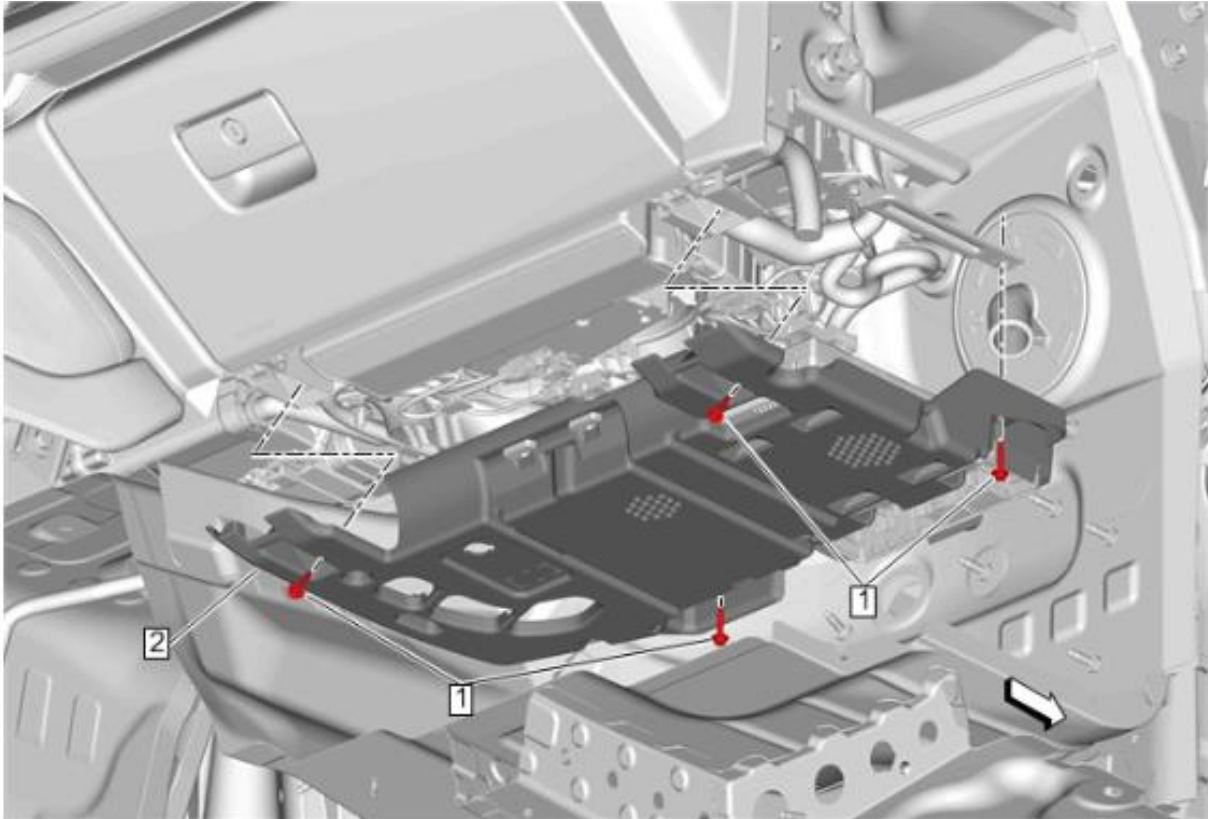

Step 2. Disconnect the wiring harness/cables from the Radio Module. Almost all of these connectors have a Connector Position Assurance (CPA) lock on them which is either red or white. These locks will need to be unlocked (pulled down generally) to unlock the connector before you are able to press in the release tab. This is where you need the automotive pick to work the connector lock down and possibly depress the locks. The Locks on the main wiring harness connectors (black and grey) are WHITE in color and small tabs. All of the locks need to be pulled down/away from the radio just exercise caution and force when doing so. We found it best to run the passenger seat back and simply lay on the passenger side floor facing up for this and just work through the connections one by one.

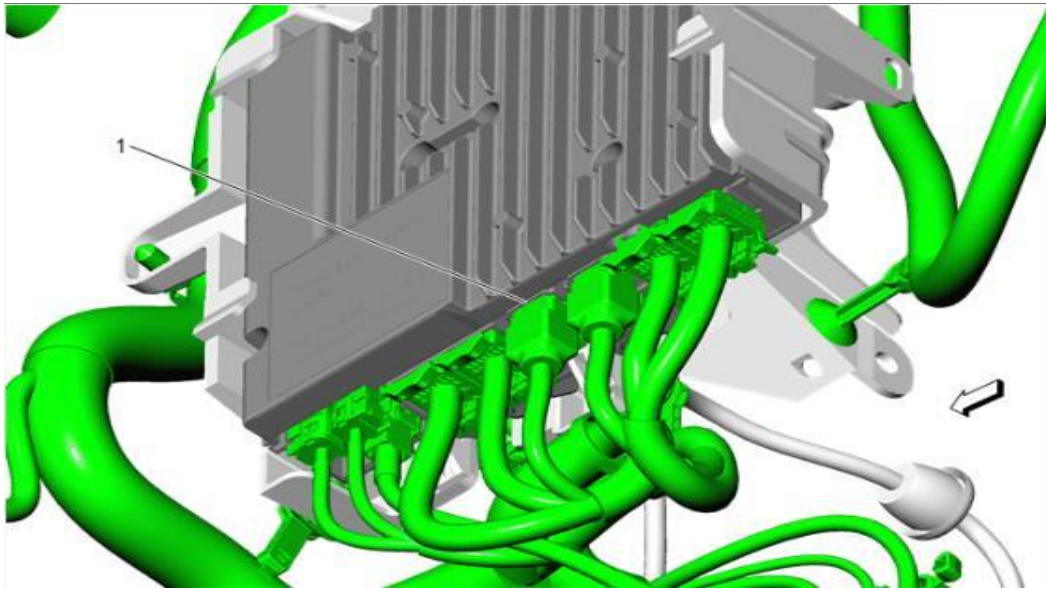

Step 3. Remove the Radio Module by depressing the two retaining clips and sliding the radio module out of the vehicle.

